

Instructions Manual

Tektronix

**DTM500 Series
Digital Thermometers**

070-9852-01



Table of Contents

| | |
|---|-----------|
| DTM500 Series Digital Thermometers | 1 |
| DTM500 Series Specifications | 3 |
| DTM500 Series Performance Verification | 7 |
| Test Equipment | 7 |
| Set Up | 8 |
| Verification Procedure | 8 |
| DTM510 Test Record | 9 |
| DTM520 Test Record | 11 |
| DTM500 Series Adjustment Procedures | 13 |
| List of Adjustments | 13 |
| Test Equipment | 13 |
| Preparation for Adjustment | 14 |
| DTM510 Adjustment Procedure | 16 |
| DTM520 Adjustment Procedure | 18 |

DTM500 Series Digital Thermometers

The Tektronix DTM510 and DTM520 are hand-held digital thermometers that can measure temperature using a variety of thermocouple probes. A K-type surface measurement bead probe comes standard with both instruments.

The DTM510 thermometer uses a single K-type probe; the DTM520 uses K- or J-type probes. The DTM520 thermometer has inputs for two probes and can perform differential measurements.

In addition, the thermometers include the following features:

- Temperature display in °C or °F
- A hold feature to freeze the display
- MIN and MAX readouts (DTM510 thermometer includes MAX only)
- A stopwatch (DTM520 only)

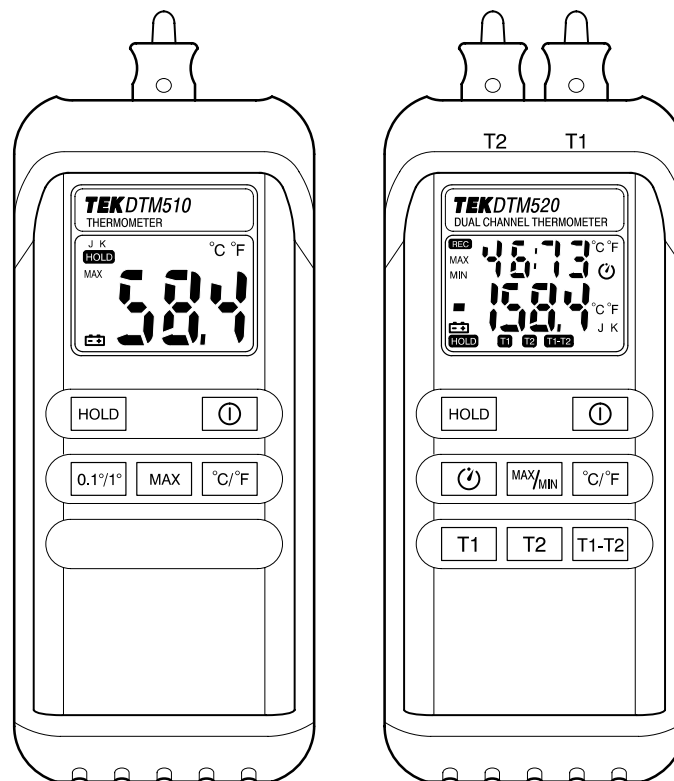

Figure 1: DTM510 & DTM520 digital thermometers

DTM500 Series Specifications

The characteristics listed in this section apply under the following conditions:

- The instrument operates in an 18° to 28° C ambient environment unless otherwise noted.
- The instrument warms up for 60 minutes.

NOTE. All specifications are warranted unless marked “typical.” Typical characteristics are not guaranteed but are provided for the convenience of the user.

Specifications marked with the ✓ symbol are checked in the performance verification procedures.

Table 1: General characteristics

| Characteristic | Description | | |
|-----------------------|-------------------------------------|------------|----------------|
| Product | Measurement Range | | |
| DTM510 | –50° to 1300° C (–58° to 1999° F) | | |
| DTM520 (K-type probe) | –200° to 1370° C (–328° to 2498° F) | | |
| DTM520 (J-type probe) | –200° to 760° C (–328° to 1400° F) | | |
| ✓ Accuracy | Temperature Range | Resolution | % of Reading |
| DTM510 | –50° to 199.9° C | 0.1° C | ±(0.2% + 1° C) |
| | –58° to 391° F | 0.1° F | ±(0.2% + 2° F) |
| | –50° to 199.9° C | 1° C | ±(0.3% + 2° C) |
| | –58° to 391° F | 1° F | ±(0.3% + 4° F) |
| | 200° to 999.9° C | 1° C | ±(0.4% + 2° C) |
| | 392° to 1831° F | 1° F | ±(0.4% + 4° F) |
| | 1000° to 1300° C | 1° C | ±(0.6% + 2° C) |
| | 1832° to 1999° F | 1° F | ±(0.6% + 4° F) |

Table 1: General characteristics (cont.)

| Characteristic | Description | | |
|-----------------------|---------------------|------------|------------------|
| ✓ Accuracy | Temperature range | Resolution | % of reading |
| DTM520 (K-type probe) | -200° to -100° C | 0.1° C | ±(0.3% + 1° C) |
| | -328° to -148° F | 0.2° F | ±(0.3% + 2° F) |
| | -99.9° to 999.9° C | 0.1° C | ±(0.1% + 0.7° C) |
| | -147.9° to 999.9° F | 0.2° F | ±(0.1% + 1.4° F) |
| | 1000° to 1370° C | 1° C | ±(0.3% + 1° C) |
| | 1000° to 2498° F | 2° F | ±(0.3% + 2° F) |
| | T1 – T2 reading | — | ±(0.3% + 2.2° C) |
| ✓ Accuracy | Temperature range | Resolution | % of reading |
| DTM520 (J-type probe) | -200° to -100° C | 0.1° C | ±(0.3% + 1.1° C) |
| | -328° to -148° F | 0.2° F | ±(0.3% + 2.2° F) |
| | -99.9° to 760° C | 0.1° C | ±(0.1% + 0.8° C) |
| | -147.9° to 999.9° F | 0.2° F | ±(0.1% + 1.6° F) |
| | 1000° to 1400° F | 2° F | ±(0.3% + 2° F) |

Table 2: General characteristics

| Characteristic | Description |
|------------------------------------|---|
| Temperature Range | ATP01 bead probe: -40° to 204° C |
| Probe Tolerance | ATP01 bead probe: ±2.2° C |
| Measurement Rate (Readings/second) | |
| DTM510 | 2.5 |
| DTM520 (T2 or T1) | 1 |
| DTM520 (T1 – T2) | 0.5 |
| Input Protection | 24 V maximum. Class III as defined in IEC 1010, Safety Requirements for Electrical equipment for measurement, control, and laboratory use. Class III equipment is equipment for connection to SELV or SELV-E circuits only. |
| Electrical Isolation T1 to T2 | 20 kΩ minimum |

Table 3: Environmental characteristics

| Characteristic | Description |
|--|---|
| Temperature coefficient <18° C or >28° C | |
| DTM510 | 0.15 × (specified accuracy) per °C |
| DTM520 | 0.1 × (specified accuracy) per °C |
| Operating temperature | 0° to 50° C (32° to 122° F) at 0% to 75% RH |
| Storage temperature | -20° to 60° C (-4° to 140° F) at 0% to 80% RH |
| Power requirements | Single standard 9 V battery (ANSI/NEDA 1604A, IEC 6F22) |
| Battery life (Alkaline) | |
| DTM510 | 250 hours |
| DTM520 | 90 hours |

DTM500 Series Performance Verification

This section contains procedures to verify that the DTM510 and DTM520 thermometers perform as warranted. If an instrument fails any of the checks, it needs adjustment and or repair. Verify the performance of your thermometer annually or whenever its accuracy or function is in question.

The performance verification procedures provide a valid confirmation of instrument electrical characteristics and function under the following conditions:

- The instrument operates in an 18° to 28° C ambient environment with a relative humidity of less than 80%.
- The instrument warms up for 60 minutes.
- The instrument remains fully assembled (do not remove the bottom cover).

The performance verification procedure should be performed annually or after every 2000 hours of operation if used infrequently.

Test Equipment

The performance verification procedures use external traceable test equipment to directly check warranted characteristics.

Alternative test equipment must meet or exceed the intended minimum requirements specified in Table 4. If you substitute equipment, you may need to modify the procedures.

NOTE. Before beginning the performance verification procedures, warm up the test equipment according to the manufacturer's recommendations.

Table 4: Performance verification test equipment

| Description | Minimum requirements | Example product |
|------------------------|--|---|
| Thermocouple Simulator | -200° to 1370° C ±0.01% (-328° to 2498° F ±0.01%) | Wavetek 9100 Universal Calibration System or Fluke 5500A Calibrator |

Set Up

To prepare for the performance verification checks, do the following.

1. Warm up the thermometer for 60 minutes.
2. Photocopy the test record for your model on pages 9 through 12 to record your test results.

Verification Procedure

Implement the following tests to verify the temperature measurement accuracy of your DTM510 or DTM520 thermometer.

1. Connect the thermocouple simulator output to the temperature probe input. For the DTM520, connect the simulator to the T1 input connector; then repeat the test using the T2 input connector.

NOTE. *Thermocouple connectors are temperature sensitive. For best measurement accuracy, do not touch the connector contacts and minimize handling of the connector housings.*

2. Set the simulator to the correct probe type. The DTM510 thermometer uses a K-type probe. The DTM520 thermometer can use either a K- or J-type probe.
3. For each of the conditions specified in the test records, do the following:
 - a. Set the thermometer Resolution to 0.1° or 1° (DTM510 only).
 - b. Set the thermometer to measure °C or °F.
 - c. Set the calibrator to each of the temperature values shown in the test record; then verify that the thermometer display reads within the specified Display minimum and maximum limits.

DTM510 Test Record

| Serial number | Procedure performed by | Date |
|---------------|------------------------|------|
| | | |

DTM510 test record

| Resolution | Temperature | Display minimum | Reading | Display maximum |
|------------|-------------|-----------------|---------|-----------------|
| 0.1° | -48.0° C | -49.1° | | -46.9° |
| | -30.0° C | -31.1° | | -28.9° |
| | 0.0° C | -01.0° | | 01.0° |
| | 30.0° C | 28.9° | | 31.1° |
| | 50.0° C | 48.9° | | 51.1° |
| | 100.0° C | 98.8° | | 101.2° |
| | -50.0° F | -52.1° | | -47.9° |
| | -22.0° F | -24.0° | | -20.0° |
| | 0.0° F | -02.0° | | 02.0° |
| | 190.0° F | 187.6° | | 192.4° |
| 1.0° | -48° C | -050° | | -046° |
| | 0° C | -002° | | 002° |
| | 50° C | 048° | | 052° |
| | 200° C | 197° | | 203° |
| | 310° C | 307° | | 313° |
| | 700° C | 695° | | 705° |
| | 810° C | 805° | | 815° |
| | 945° C | 939° | | 951° |
| | 1280° C | 1270° | | 1290° |
| | -50° F | -054° | | -046° |
| | 0° F | -004° | | 004° |
| | 590° F | 584° | | 596° |
| | 1292° F | 1283° | | 1301° |
| | 1733° F | 1722° | | 1744° |
| | 1980° F | 1964° | | 1996° |

DTM520 Test Record

| Serial number | Procedure performed by | Date |
|---------------|------------------------|------|
| | | |

DTM520 test record

| Probe type | Temperature | Display minimum | Reading | Display maximum |
|------------|-------------|-----------------|---------|-----------------|
| K | -198.0° C | -199.6° | | -196.4° |
| | -99.0° C | -99.8° | | -98.2° |
| | 0.0° C | -0.7° | | 0.7° |
| | 50.0° C | 49.2° | | 50.8° |
| | 500.0° C | 498.8° | | 501.2° |
| | 998.0° C | 996.3° | | 999.7° |
| | 1360° C | 1355° | | 1365° |
| | -320° F | -323° | | -317° |
| | -146° F | -147.5° | | -144.5° |
| | 0.0° F | -1.4° | | 1.4° |
| | 100° F | 98.5° | | 101.5° |
| | 500° F | 498.1° | | 501.9° |
| | 990° F | 987.6° | | 992.4° |
| | 1980° F | 1972° | | 1988° |
| | 2480° F | 2471° | | 2489° |

DTM520 test record (cont.)

| Probe type | Temperature | Display minimum | Reading | Display maximum |
|------------|-------------|-----------------|---------|-----------------|
| J | -198.0° C | -199.7° | | -196.3° |
| | -99.0° C | -99.9° | | -98.1° |
| | 0.0° C | -0.8° | | 0.8° |
| | 50.0° C | 49.1° | | 50.9° |
| | 100.0° C | 99.1° | | 100.9° |
| | 500.0° C | 498.7° | | 501.3° |
| | 755.0° C | 753.4° | | 756.6° |
| | -320.0° F | -323.2° | | -316.8° |
| | -146.0° F | -147.7° | | -144.3° |
| | 0.0° F | -1.6° | | 1.6° |
| | 100.0° F | 98.3° | | 101.7° |
| | 500.0° F | 497.9° | | 502.1° |
| | 990.0° F | 987.4° | | 992.6° |
| | 1390° F | 1384° | | 1396° |

DTM500 Series Adjustment Procedures

This section contains procedures to adjust DTM510 and DTM520 thermometers. If your thermometer fails a performance requirement, use these procedures to return it to factory specifications.

In this section you will find the following information:

- A list of adjustments
- A list of test equipment needed to make the adjustments
- Instructions on how to prepare the instrument for adjustment
- Step-by-step adjustment procedures

The procedures in this section do not verify performance. To confirm that your thermometer meets factory specifications, implement the procedures in the *DTM500 Series Performance Verification* section.

List of Adjustments

Use the adjustments listed in Table 5 to return DTM510 and DTM520 thermometers to factory calibration.

Table 5: DTM510 and DTM520 adjustments

| |
|-----------------------------|
| DTM510 Adjustment Procedure |
| DTM520 Adjustment Procedure |
| 2000 mV Calibration |
| Gain Calibration |
| 0° C Calibration |

Test Equipment

To ensure accurate adjustments, use the following or equivalent test equipment. If you substitute equipment, always choose instruments that meet or exceed the minimum requirements specified in Table 6.

NOTE. Before making any adjustment, warm up the test equipment according to the manufacturer's recommendations.

Table 6: Adjustment test equipment

| Description | Minimum requirements | Examples |
|------------------------------|--|--|
| Thermocouple Simulator | -200 to 1370° C \pm 0.01% (-328 to 2498° F \pm 0.01%) | Wavetek 9100 Universal Calibration System or Fluke 5500A Calibrator |
| DC Voltage Source (DTM520) | 10 mV to 2 V, 0.01% accuracy | |
| Thermocouple Extension Cable | K-type thermocouple wire with SMP male end connectors | Omega TECK-10-10 |
| Transition Adapter (DTM520) | SMP female-to-male banana | Omega TAS-U-5 |

Preparation for Adjustment

The following guidelines apply to all DTM510 and DTM520 adjustments:

- Perform all adjustments in a 21° to 25° C ambient environment with a relative humidity of 75% or less.
- Warm up the thermometer for at least 30 minutes.
- Do not alter any setting without reading the entire adjustment procedure first.
- Do not alter a setting unless a performance characteristic cannot be met at the current setting.
- Read the *Safety Summary* at the beginning of this manual.

NOTE. Thermocouple connectors are temperature sensitive. For best measurement accuracy, do not touch the connector contacts and minimize handling of the connector housings.

Open the Thermometer

To make internal adjustments, you must open the thermometer case and remove the circuit board (see Figure 2 or Figure 3).

1. Unplug the thermocouple(s).
2. Lay the thermometer face down on a flat work surface.
3. Remove the single screw from the battery compartment cover with a Phillips-head screwdriver and remove the battery compartment cover.
4. Remove the four screws from the corners of the thermometer.
5. Lift the top end of the cover and remove both the cover and the cap.
6. Remove the screws from the corners of the circuit board (the DTM510 thermometer has three screws; the DTM520 thermometer has four) and gently lift the circuit board out of the case.
7. Remove the rubber keypad from the case.
8. Lay the circuit board face up.
9. Place the rubber keypad on the circuit board so it can be used to operate the thermometer.

To reassemble the thermometer following the adjustments, perform steps 3 through 7 above in reverse order.

DTM510 Adjustment Procedure

This section describes how to adjust the DTM510 thermometer. To properly adjust the thermometer, perform the following steps in sequential order.

1. Open the thermometer as described in the previous section.
2. Turn on the thermometer and allow it to warm up for at least 30 minutes.
3. Connect the thermocouple simulator to the probe connector.
4. Set the simulator probe type to K.
5. For each row in Table 7, set the thermometer and simulator as shown; then adjust the specified test point until the displayed temperature is within the proper limits. Figure 2 shows the location of the adjustment points.

Table 7: DTM510 adjustment procedures

| Thermometer setting | | Simulator setting | | |
|---------------------|------------|-------------------|------------|--------------------|
| C/F | Resolution | Temperature | Test point | Temperature limits |
| C | 0.1° | 0° C | VR1 | -00.1° and 00.1° |
| F | 1° | 1000° C | VR3 | 1831° and 1833° |
| C | 1° | 1000° C | VR5 | 999° and 1001° |
| C | 0.1° | 190° C | VR2 | 189.9° and 190.1° |
| F | 0.1° | 0° C | VR4 | 31.9° and 32.1° |
| C | 1° | 1000° C | VR3 | 999° and 1001° |

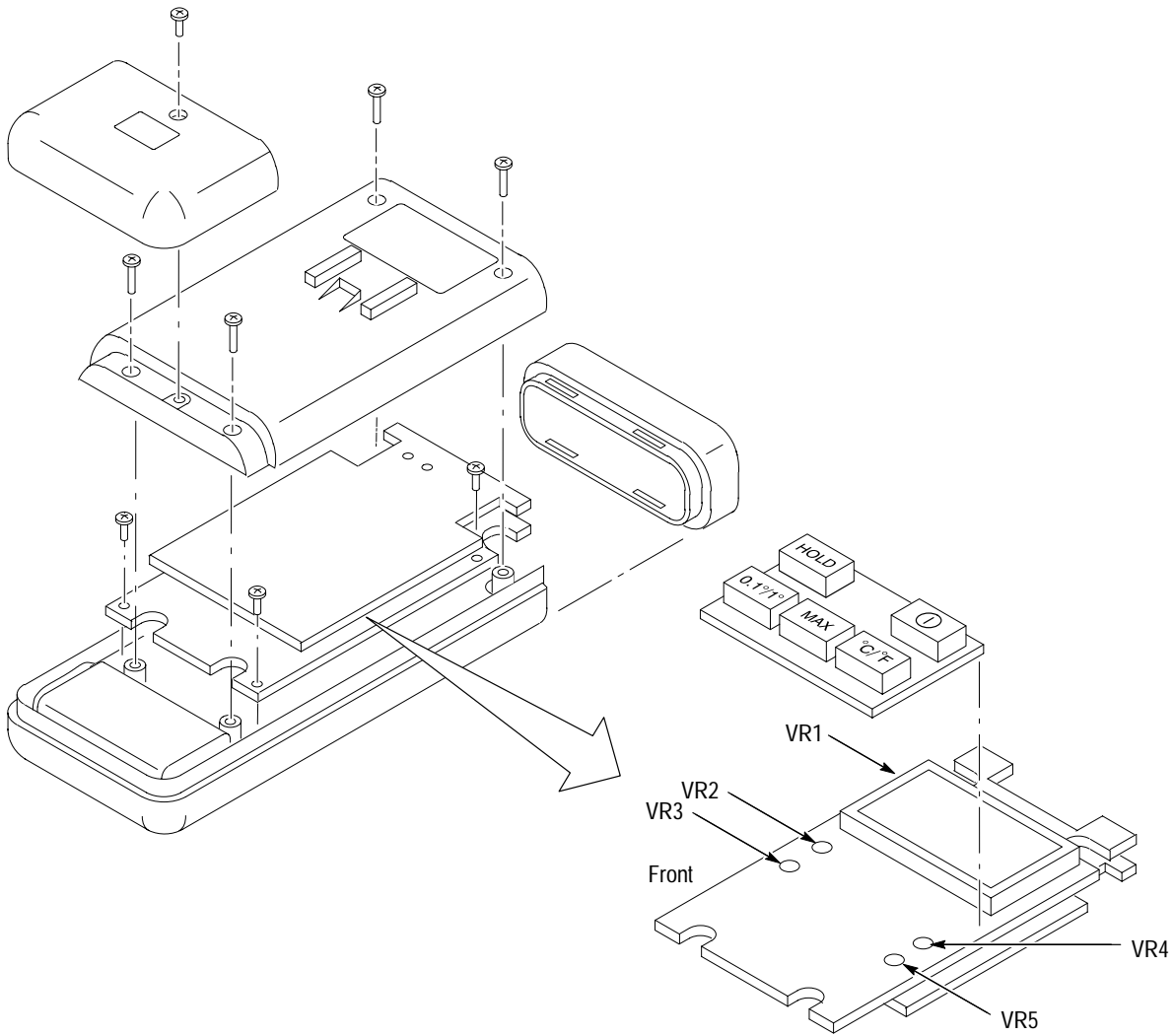

Figure 2: DTM510 Thermometer disassembly and adjustment locations

DTM520 Adjustment Procedure

This section describes how to adjust the DTM520 thermometer. To properly adjust the thermometer, perform the following steps in sequential order. Figure 3 shows the location of the test and adjustment points.

1. Open the thermometer. (See page 15 for instructions.)
2. Solder a jumper across R25.
3. Turn on the thermometer and allow it to warm up for at least 30 minutes.

2000 mV Calibration

Use the following procedure to perform a 2000 mV calibration.

1. Press T2 once to access the T2 mode.
2. Install a jumper across the test points marked JP1.
3. Connect the DC voltage source to the T1 probe connector. The composition of both lead wires should be identical.
4. Set the DC voltage source output to $+2000.0 \text{ mV} \pm 0.01\%$.
5. Adjust VR2 until the display shows 2000.0° . (The first digit of the temperature appears at the upper right-hand corner of the display.)
6. Disconnect the DC voltage source.
7. Remove the R25 jumper. (Do not remove the JP1 jumper.)

Gain Calibration

Use the following procedure to perform a gain calibration.

1. Press $^\circ\text{C}/^\circ\text{F}$ until “1L” appears in the upper left-hand corner of the display.
2. Set the DC voltage source output to $+50.000 \text{ mV} \pm 0.01\%$.
3. Reconnect the DC voltage source to the T1 probe connector.
4. Adjust VR3 until the display shows 000.0° . (The first digit of the temperature appears at the upper right-hand corner of the display.)
5. Disconnect the DC voltage source.
6. Remove the JP1 jumper.

0° C Calibration

Use the following procedure to perform a 0° calibration.

1. Connect the thermocouple simulator to the T1 probe connector.
2. Set the thermocouple simulator and thermometer probe types to K.
3. Set the thermocouple simulator to 0° C.
4. Adjust VR1 until displayed temperature is between -00.1° and 00.1° .
5. Disconnect the thermocouple simulator.

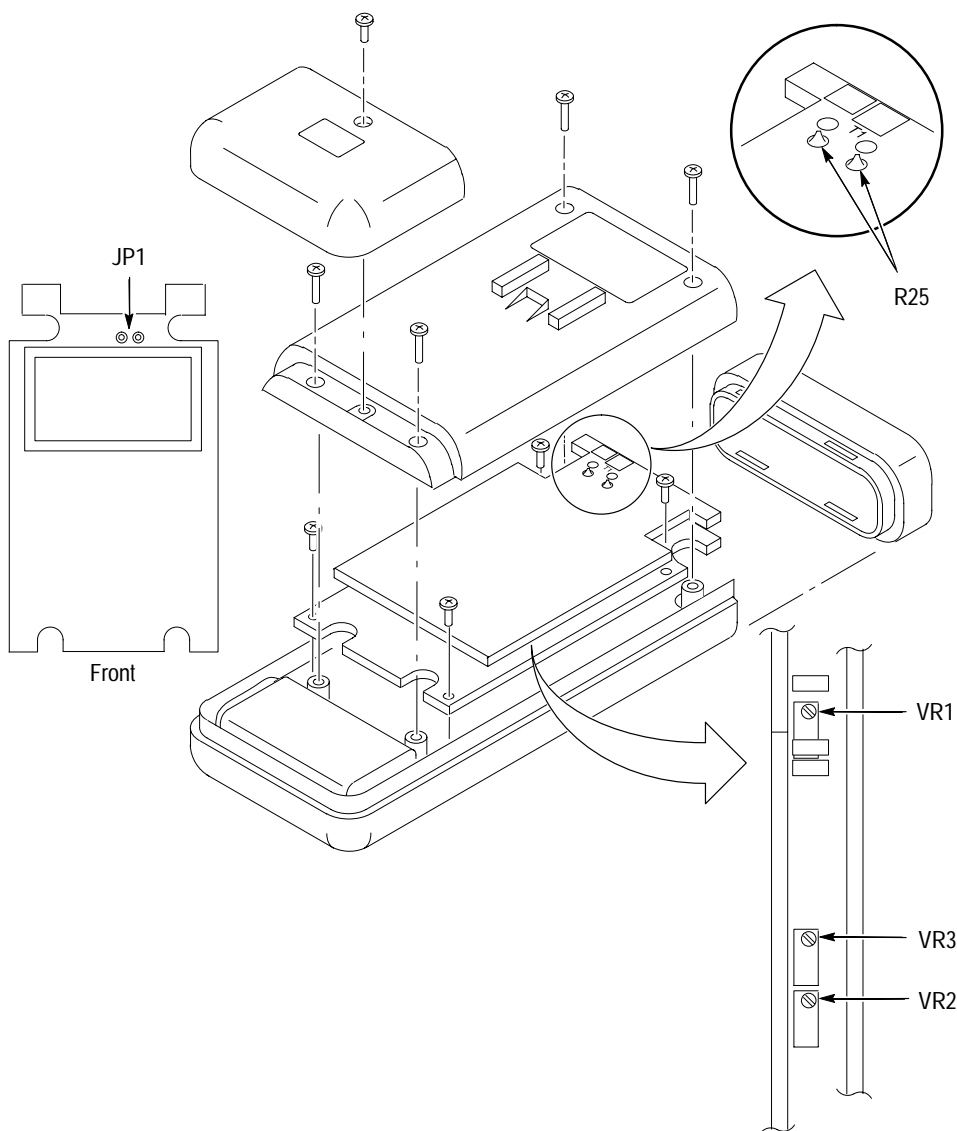

Figure 3: DTM520 Thermometer disassembly, test points, and adjustment locations

